

Specification

Stainless Steel Expansion Tank



Features:

- Shock Arrester for Tankless and POU Water Heaters with 2 gallons or less of total water volume
- Designed to protect the heat exchanger on tankless water heaters by relieving excess pressure in the system
- Tank includes a 50 PSI factory precharge
- Entire tank is constructed of 304 stainless steel
- 1/2" NPTM 304 stainless steel connection
- UV-resistant and approved for outdoor installation
- Butyl membrane diaphragm
- To be installed on the cold side of the tankless water heater
- IAPMO Listed

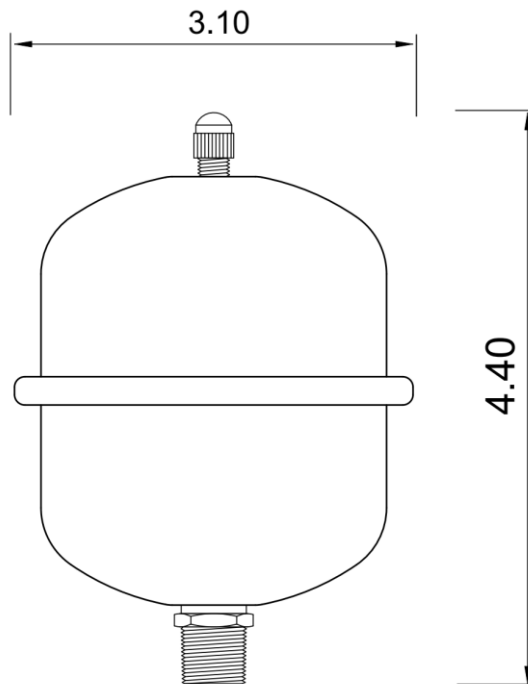

Unit: inches

Model#	Description
EXP-TANKLESS	Tankless Heater Expansion Tank, Stainless Steel with 1/2" NPT

LEAD FREE

NSF/ANSI/CAN 61

